

# Swell FormPro

## User & Technical Manual



Swell Touch Paper



---

Contents:

<b>Introduction</b> .....	3
<b>Safety Information</b> .....	4
<b>Main Features</b> .....	5
<b>Description</b> .....	6
<b>Operation</b> .....	7
<b>Specifications</b> .....	9
<b>Troubleshooting</b> .....	10
<b>Technical Manual</b> .....	11-22

## Introduction

---

The Swell Form Pro is the high-speed commercial/production version of our popular Swell Form machine, which is used to create stunning tactile graphics and tactile diagrams. It was designed to improve productivity, as the machine can process our Swell Touch paper up to 7 times faster than the standard Swell Form machine.

The speed specifications of the Swell Form Pro are amazing: up to 34 A4 pages per minute (A4 and 8.5x11" size, portrait side-to-side), and up to 25 A4 and 8.5x11" pages per minute in landscape orientation; and up to 17 A3 and 11x17" pages per minute (in landscape orientation).

The Swell Form Pro was designed and produced with the braille production facility and commercial customers in mind, as its speed and heavy-duty build quality ensures that it is ready for extended production cycles.

The Swell Form Pro has several safety features, and a simple to use and intuitive user interface.

## Safety Information

---



**Caution: Risk of electric shock!  
No user serviceable parts inside!**



**Caution: Hot surface!  
Always allow to cool before  
touching the top cover!**

- The Swell Form Pro should only be operated in well-ventilated areas.
- Always ensure that the machine is in the correct working position, and stable on the ground.
- Do not use any other type of paper besides Swell Touch.
- Ensure Swell Touch paper is flat when entering the machine, and that any curl or bent edges have been reduced.
- If the paper jams, immediately stop the machine and turn it off. Once the power is off, remove the paper before turning it back on and feeding more paper.
- Do not block any fans/cooling vents.
- Leave adequate space behind the machine for proper paper exit.
- Avoid any operational action that may cause a hazardous situation.
- Do not use any kind of liquid to clean the machine.

## Main Features

---

### Functional features:

- Paper size: A2, A4, 8.5x11", A3, 11x17" and everything in between.
- Maximum speed: up to 34 A4 / 8.5x11" pages per minute; up to 17 A3 / 11x17" pages per minute.
- Speed regulation from 10 to 25 (approx. 10 - 25ppm, A4 paper, landscape orientation).
- Recommended start up speed: 15 pages per minute, and then adjust accordingly as machine warms up.
- Large, 5-inch LCD display that shows current paper speed value, lamp and motor status, internal frame temperature (IntT) and external frame temperature (ExtT). Please note temperature is shown in °C.
- Beeps that notify user of start/stop commands, speed regulation and paper feed detection.
- Start/Stop system with belt cooling mechanism (belt stops 15 seconds after the lamp has turned off).
- Soft-start mechanism ensures long life of the heating lamp.
- Automatic paper detection avoids the need for "start" commands - the fuser automatically detects the paper feed, keeping the lamp on as long as paper is detected.

\*Note: repeated feeding of paper without intervals, with the edges of the paper overlapped will result in the machine stopping for safety reasons. \*

### Safety features:

- Emergency button turns off the power supply, requiring a manual "Reset" to reset the power supply.
- For safety reasons, a continued press on the start/stop button results in the "stop" status (lamp off).
- Real-time indication of external frame temperature (ExtT) and internal frame temperature (IntT).
- Automatic audible high temperature warning resulting in an error message - "Maximum Temperature - Wait".
- Conveyor blocked detection with audible warning system and error message - "Start" inhibition - "Belt blocked".
- The secondary safety system protects against excess temperature in the internal frame (turns off the fuser until the temperature decreases).
- Venting system for direct connection to the extractor hood.

## Description

---

### Pro Heater II Front panel:

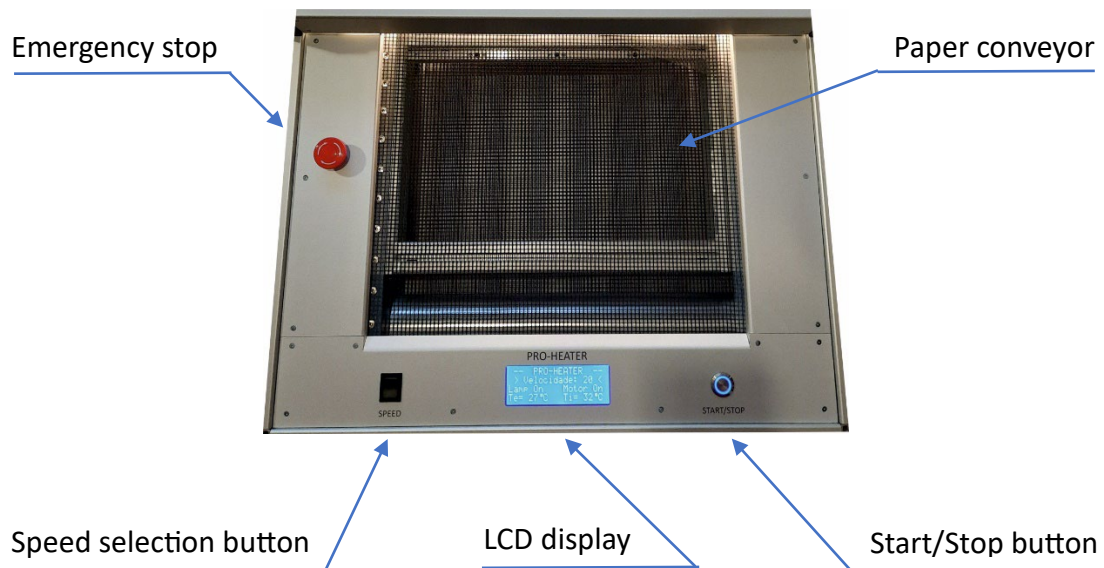

### Swell Form Pro Heater II LCD display information:

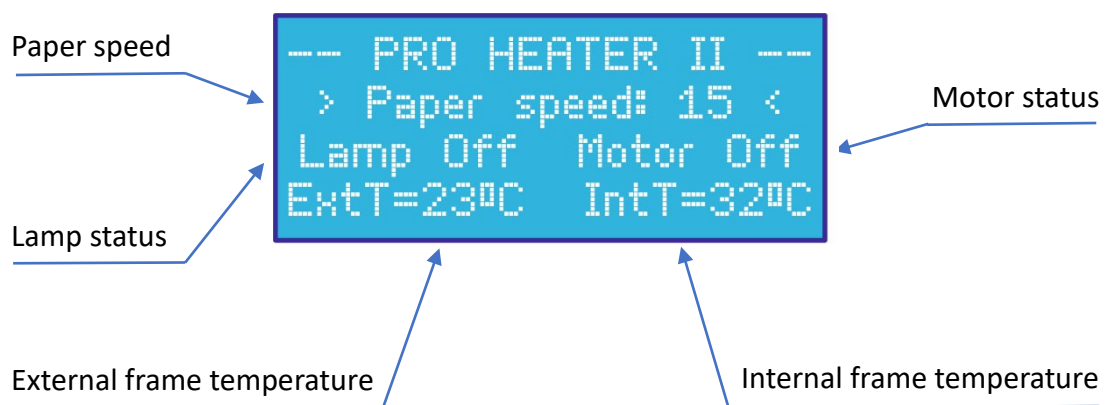

### **Swell Form Pro Heater II operation:**

1. Turn the machine on. A series of short beeps will confirm that the machine is starting up. This information is also shown on the LCD display with the message "Starting Up...".
2. After the start-up sequence, only the cooling fans should be heard. The status will be shown on the LCD display, including internal frame and external frame temperatures. The belt motor and lamp will be "Off".
3. Set the paper speed to the desired value. When the machine is cool, a lower value is needed for the Swell Touch to work properly. After a few minutes of use, the machine will be warmer, and the paper speed may be increased. Please note that for consistent results, the machine may need to be pre heated, and the top paper speed will only be achieved after the machine reaches its normal operating temperature.
4. Press the "Start/Stop" button. A beep will be heard, and the belt will start at the selected speed. You may now feed the Swell Touch facing up onto the conveyor belt. Once the paper is detected, a second beep will be heard, and the paper will be pulled through the machine.
5. From the rear of the machine, paper should fall into the collection tray, or onto a table if no collection tray is used.
6. If no additional paper is detected, the lamp will go off after approximately 30 seconds. The belt will stop approximately 45 seconds after the last paper detection, ensuring proper belt cooling.
7. During continuous use, a beep will be heard whenever a new sheet of paper is detected, making it unnecessary to press the "Start" button again. Please do not overlap sheets of paper (not allowing gaps between sheets) as this will cause the lamp to turn off for safety reasons.
8. Pressing the "Start/Stop" button while the lamp is on will issue a "stop" command, provided enough time has elapsed from the last "start" command. This will turn off the lamp, saving energy and extending lamp life.

## Operation

---

### Display information:

```
American Thermoform
-- PRO HEATER II --

Starting Up...
```

Swell Form Pro is starting up. This sequence lasts a few seconds. A continuous beep is heard during the start-up sequence.

```
-- PRO HEATER II --
> Paper speed: 15 <
Lamp Off  Motor Off
ExtT=23°C  IntT=32°C
```

Swell Form Pro is now ready after the start-up sequence is completed. The lamp is off, and the motor (belt) is off. The external frame and internal frame temperatures are displayed.

```
-- PRO HEATER II --
> Paper speed: 15 <
Lamp On   Motor On
ExtT=23°C  IntT=32°C
```

After a "Start" command, the lamp and motor turn on, and Swell Touch paper can be placed and fed through the machine.

```
-- PRO HEATER II --
> Paper speed: 15 <
Lamp Off  Motor On
ExtT=23°C  IntT=32°C
```

If no further Swell Touch is fed into the machine, the lamp will go off after 30 seconds. The belt will stop after an additional 15 seconds, allowing the belt to cool down.

```
-- WARNING --
Max. Temperature!

-- Please wait! --
```

If an extremely high temperature is detected, either in the internal or external frames, the lamp shuts down and a warning message is shown. After cooling down, normal operation may resume.

```
-- WARNING --
Belt blocked!
Turn off the fuser
and remove the lock!
```

If a mechanical malfunction is detected (belt blocked, or loose), a warning message is shown. The machine must be turned off, and the cause investigated. Do not start the machine until the malfunction is fixed.



## Specifications

---

Swell Form Pro Heater II specifications:

- Paper size: A2, A4, 8.5x11", A3, 11x17", and everything in between.
- Maximum speed: up to 34 A4 / 8.5x11" pages per minute; up to 17 A3 / 11x17" pages per minute.
- Power supply: 220 - 240V, 50/60Hz.
- Power consumption: 2100W max.
- Ambient operating temperature: 0 - 40°C, 32 - 104°F.
- Dimensions: 100cm / 40" (L) x 75cm / 30" (W) x 96 cm / 38" (H).
- Weight: 48kg / 105 pounds.
- Fusing lamp rating: 2000W.
- Power inlet fuse rating: 5x20mm T10AH 250V (slow-blow, high breaking).

## Troubleshooting

---

### Troubleshooting:

The machine does not turn on:

- Confirm that the machine is plugged in correctly (both the cable into the machine input power receptacle, and into the wall socket).
- Confirm that the electrical socket is getting power.
- Check/replace fuse located in the input power receptacle.

Paper jams:

- Immediately press the emergency stop button.
- Turn off the machine using the main power switch.
- Remove the jammed paper.
- Confirm that there is no paper left in the conveyor belt mechanism.

Paper swelling issues:

- Ensure that the machine is warmed up and the speed isn't too fast.
- If the machine is cold, or has just been turned on, slow down the speed.
- As the machine warms up, increase the speed.
- If the machine is warmed up, but speed is kept low, burning of the paper/graphic may occur.

If you notice any mechanical malfunction, turn the power off and contact American Thermoform / Zychem, or your distributor. Do not try to power the machine on again until the malfunction has been corrected.

## Power and fuses

---

### 1 – Power inlet module:

- IEC inlet, EMI filter, switch and single fuse
- Fuse rating: T10AH / 250V (10A, slow-blow, high breaking capacity)

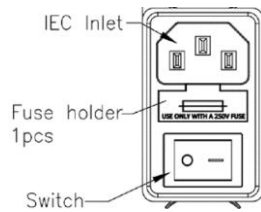

### 2 – Power Supply Unit (PSU):

- Input: 85-264 Va.c., 50/60Hz
- Output: 12V d.c. 60W



### 3 – Emergency switch

- 10A, 250V, double pole, 40mm mushroom button



### 4 – PCB fuse

- There is a secondary fuse in the main PCB, T12AH, 250V (10A, slow-blow, high breaking capacity)

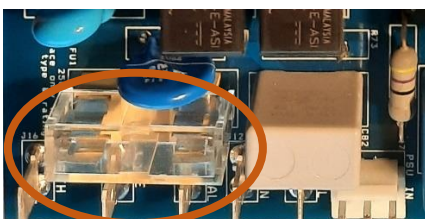

# Unit overview

---

## Unit overview – main components

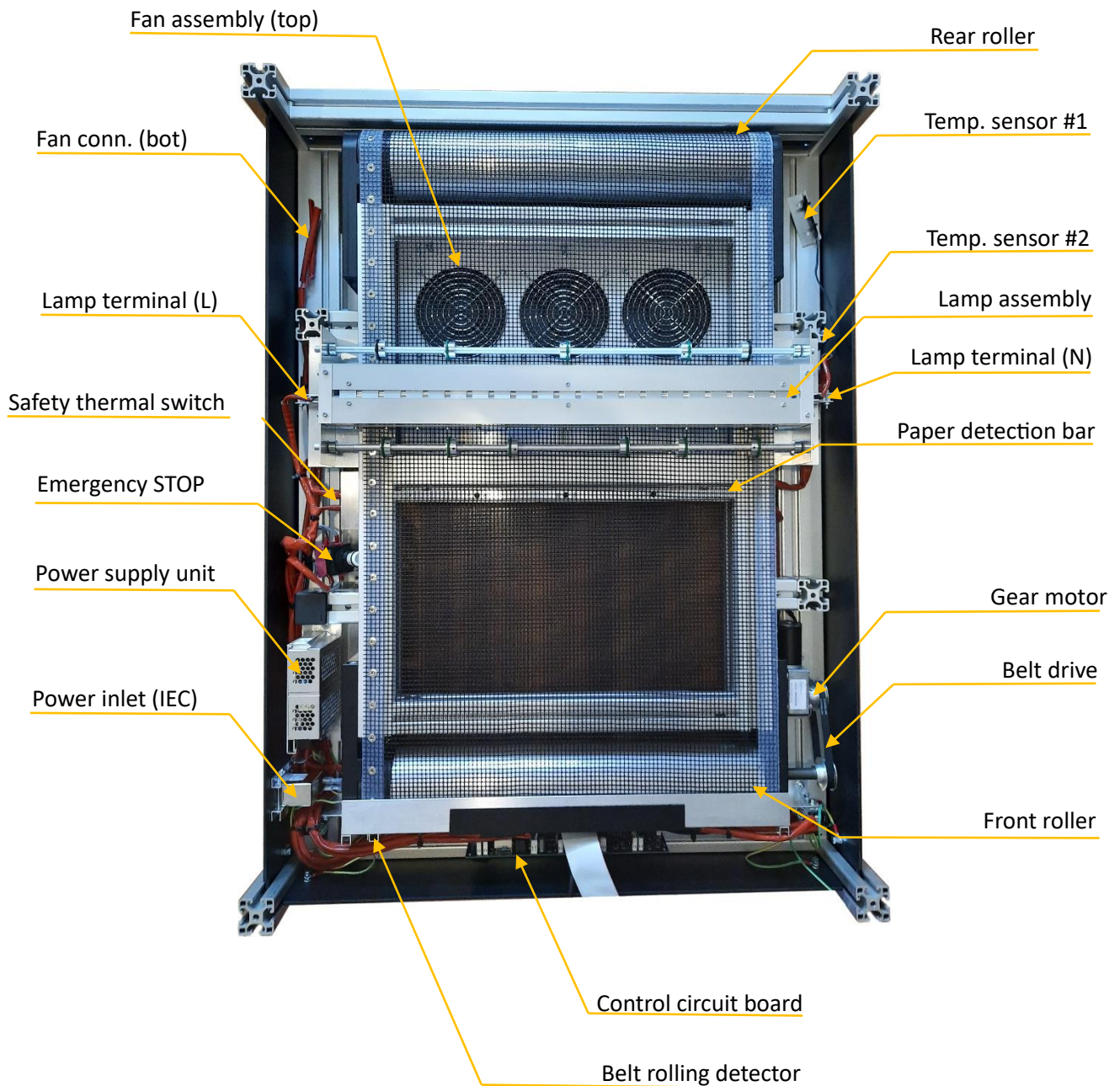

# PCB Connections

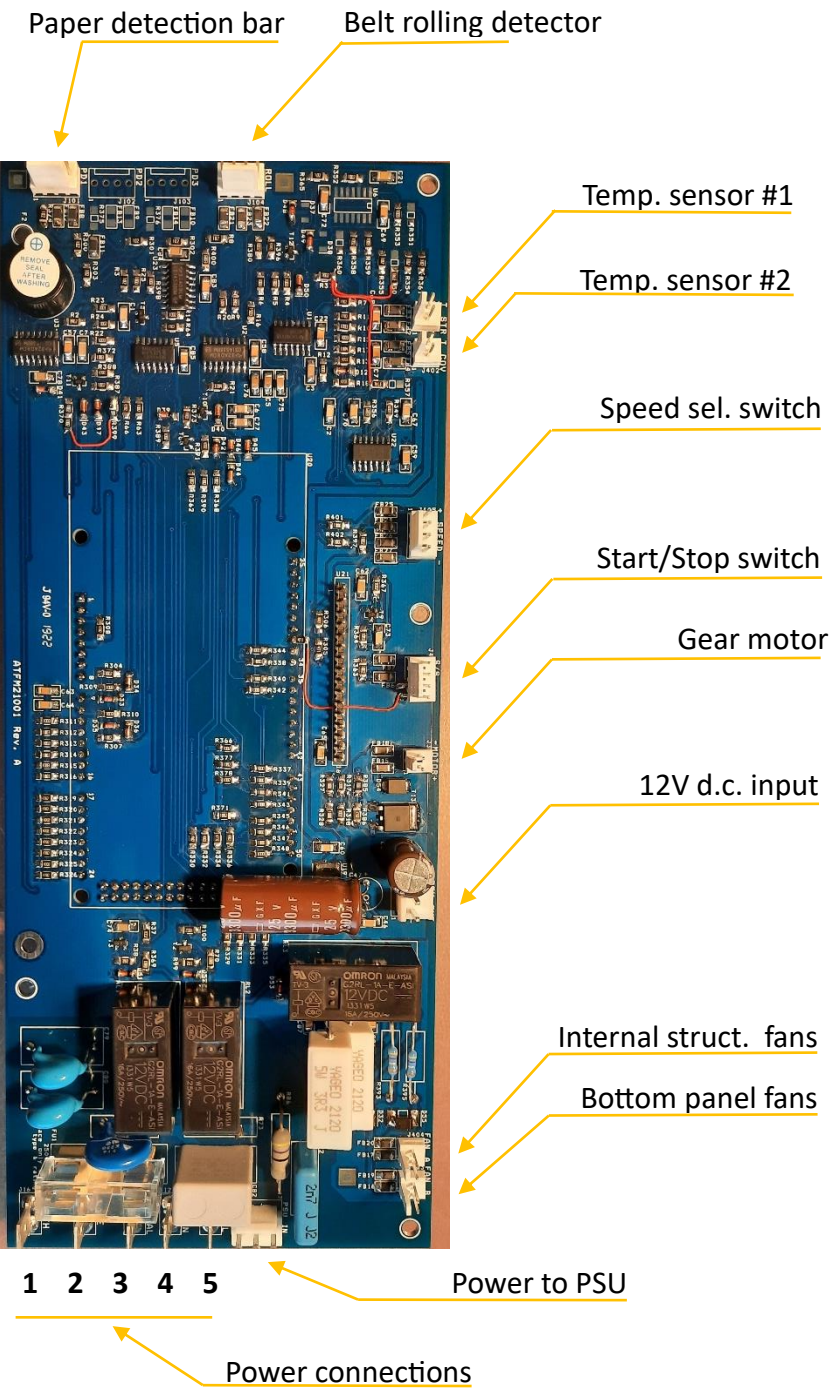

Terminal	Function
1	EARTH
2	LIVE
3	NEUTRAL
4	LAMP (N)
5	LAMP (L)

## Disassembly (top cover)

---

### Top cover disassembly instructions



Remove the 8 screws from the top cover (front and back).



Remove the top cover, lifting it from the rear and bending the rear part slightly outwards.



If needed, remove the rear paper collection plate, removing both screws.



The lamp assembly is now accessible

## Disassembly (front panel)

---

### Front panel disassembly instructions



Remove the 14 screws from the front panels.

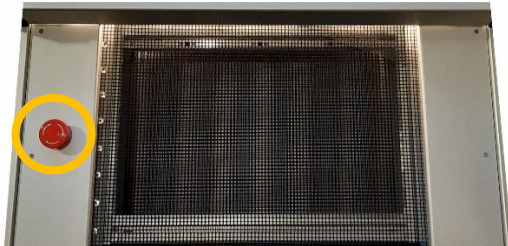

Remove the red mushroom button from the emergency stop switch, unscrewing it from the switch body.

Remove the main switch nut that attaches it to the panel.

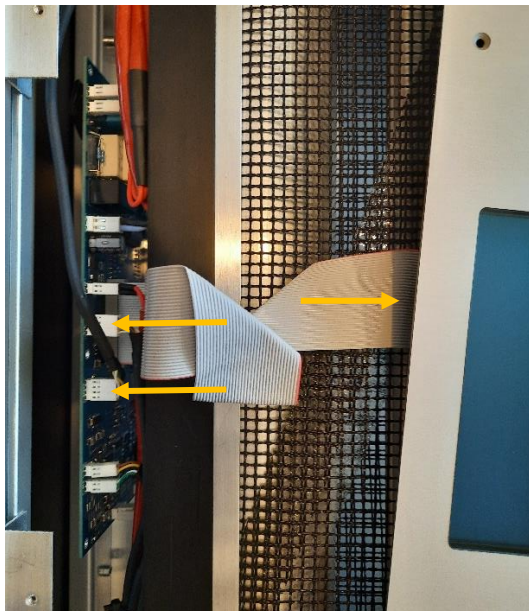

Gently remove the front lateral panels and the main front panel that contains the LCD display.

Disconnect the flat-cable from the LCD display module with care.

Disconnect the SPEED switch and the START/STOP switch from the PCB.

## Adjusting the lamp

---

### Adjusting the IR lamp

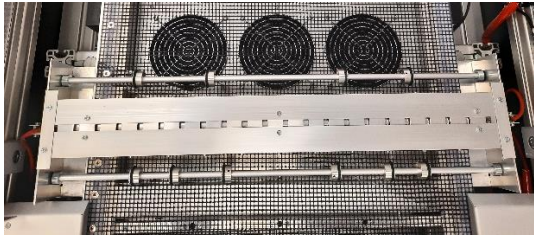

Remove the top cover to gain access to the lamp assembly.



Adjust both height adjustment screws on both lamp holders. Adjust the lower nut and the one below the aluminum plate to perform this operation.

The lamp burning position is  $9\pm 1$ mm from the surface of the swell paper.

Make sure the lamp is perfectly horizontal.



Make sure the two upper nuts are perfectly tightened.



## Replacing the lamp

---

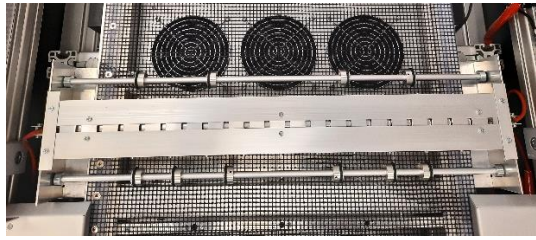

Remove the top cover to gain access to the lamp assembly.

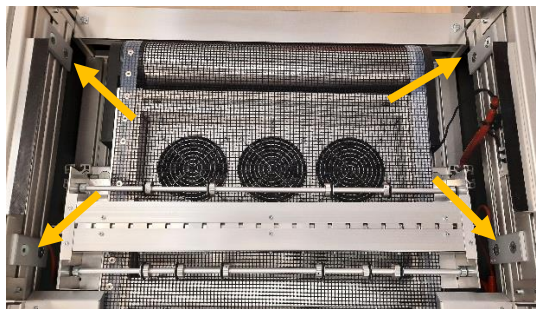

To ease the rest of the operation, it is recommended to remove the two upper lateral aluminum profiles, releasing the four tabs.



Disconnect the lamp at both ends ("Fast-On" terminals).

Remove the four M4 screws, washers and nuts from both sides of the lamp assembly.

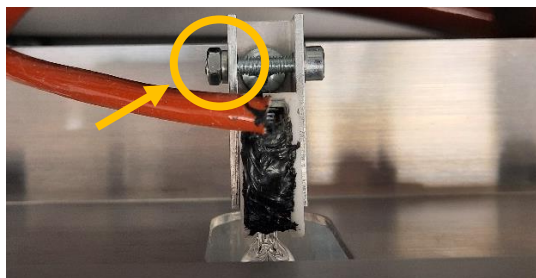

Release the M3 screws on both lamp holders. The lamp will come loose.

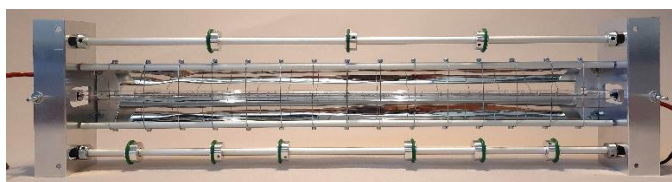

Gently slide the lamp within the reflector and remove it from one of the sides.

Take care not to scratch the reflector.

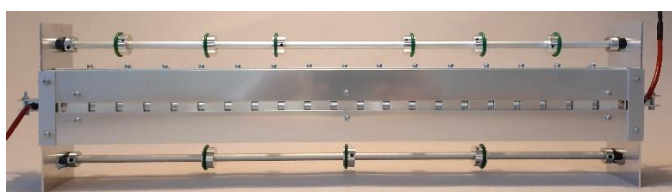

Install the new lamp following the reverse order and tighten the M3 screws on both lamp holders.

Adjust lamp height as per the previous instructions.

## Sensors and motor belt

---

### Safety thermal switch

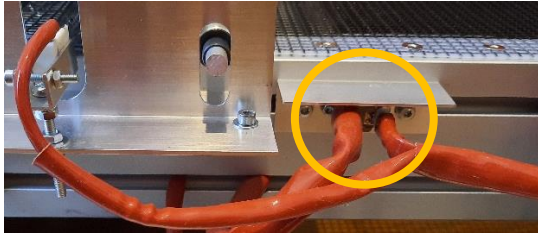

There is a 70°C safety thermal switch mounted on the inner frame, in series with the lamp (L) terminal.

### Temperature sensors

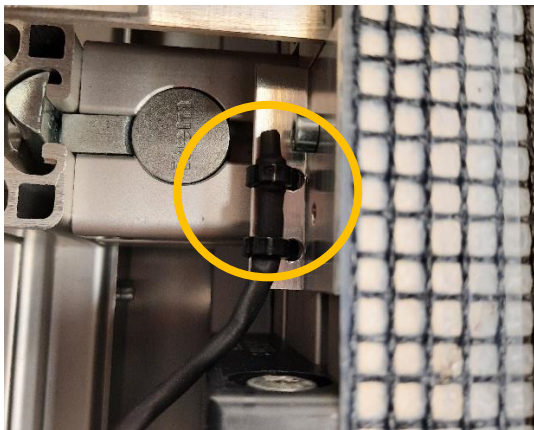

Temperature sensor #1: acquires the temperature of the internal frame.

This temperature is displayed in the LCD: "Ti".

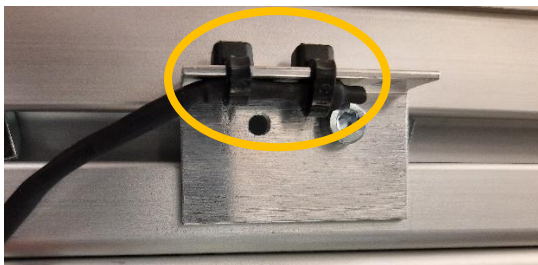

Temperature sensor #2: acquires the temperature of the external frame.

This temperature is displayed in the LCD: "Te".

## Sensors and motor belt

---

### Belt rolling detector



The belt rolling detector detects the correct rolling when the motor is "ON" and the lamp is "ON".

If the belt comes loose or is otherwise blocked, the lamp will immediately shut off, and the motor stopped.

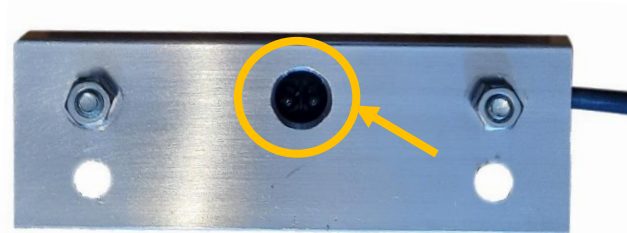

A warning message will be issued, and the machine should be switched off and the cause investigated.

Keep the sensor clean, otherwise it may incorrectly detect a fault.

### Paper detection bar

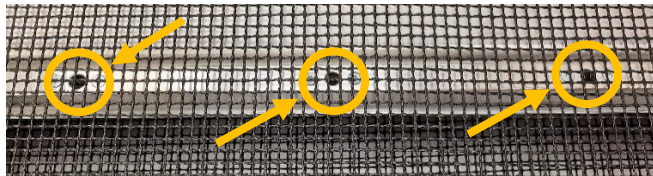

The paper detection bar contains 3 sensors that detect paper feed after a "Start" command.

Keep the sensors clean, otherwise paper feed detection may not work properly.

### Motor belt

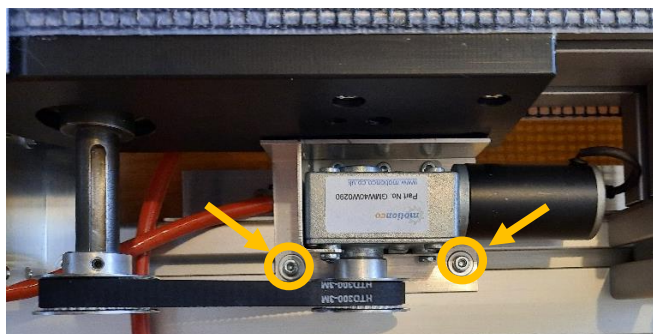

The motor belt tension is adjusted by two M4 screws that attach the motor assembly to the frame of the machine.

The drive belt should be adjusted so that it is not too loose (or it may skip teeth) or too tight (it can strain the motor).

## Paper belt tension adjustment

---

### Paper belt adjustment

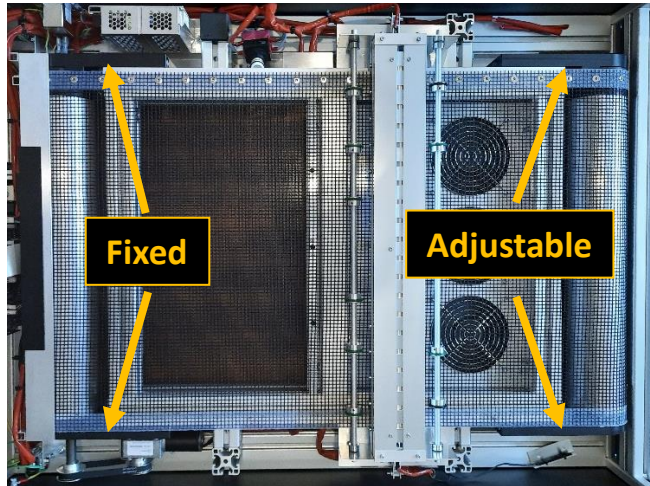

The two roller ends next to the paper exit are adjustable, allowing for paper belt tension adjustment.

The paper belt should be adjusted so the belt rolls centered, and there isn't much strain in the transmission.



Release the four screws on both rear roller ends.

This will allow the adjustment of the paper belt.

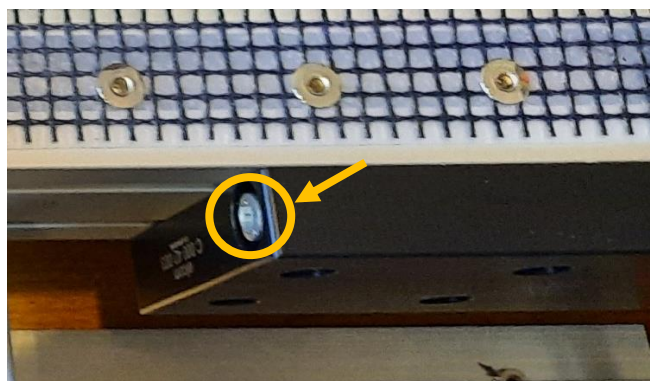

Adjust the paper belt tension:

- Clockwise: tightens the paper belt.
- Counter clockwise: loosens the paper belt.

Allow the belt to roll for 10 minutes, and readjust if necessary.

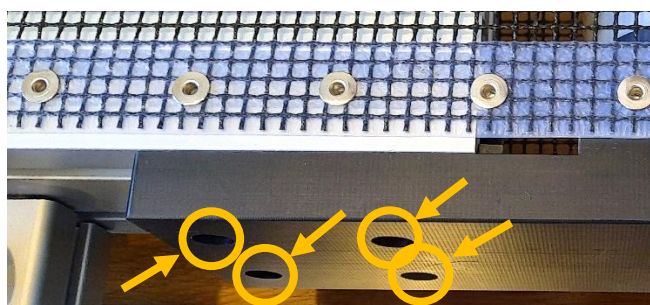

After the paper belt is properly adjusted, make sure to re-tighten all four screws on both roller ends.

# Firmware update

## Firmware update procedure



Remove the eight screws that hold the main front panel that holds the LCD display.

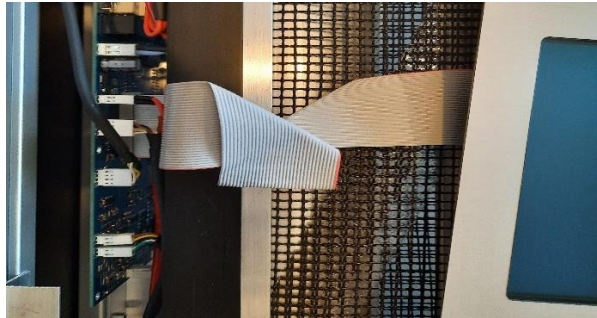

Gently pull aside the front panel. Be sure to place it on an isolated surface.

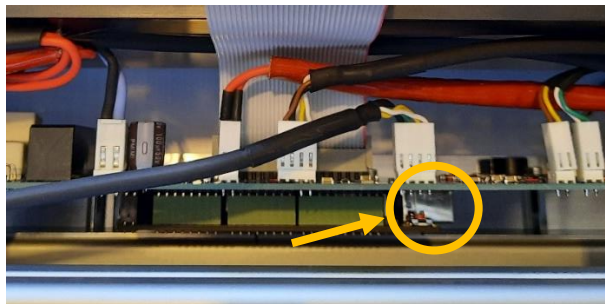

Gain access to the USB Type B port located on the CPU module.

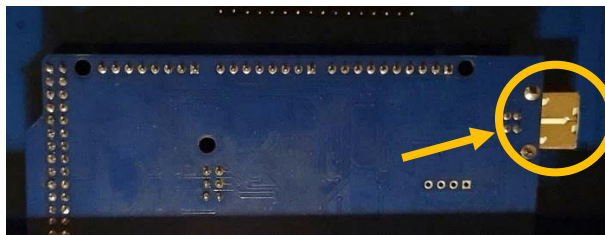

Connect a USB-A to USB-B cable from the PC or Laptop to the CPU module.

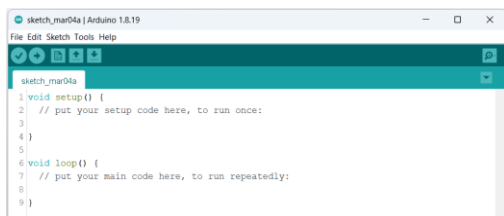

Use the Arduino IDE to update the firmware (Mega 2560 board).

Install and run the Arduino IDE.

## Firmware update (continued)

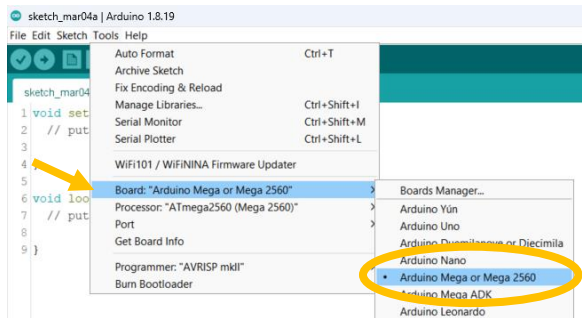

From *Tools* select the Arduino Mega or Mega 2560 board.

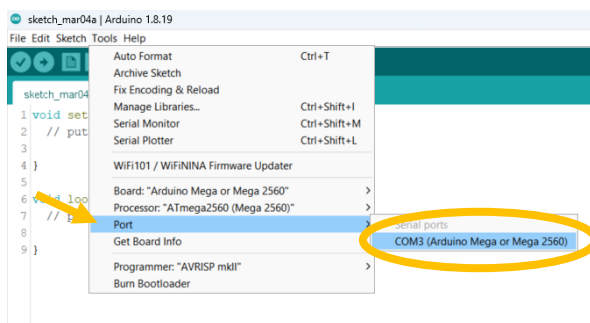

From *Tools* select the port associated to the Arduino Mega or Mega 2560.

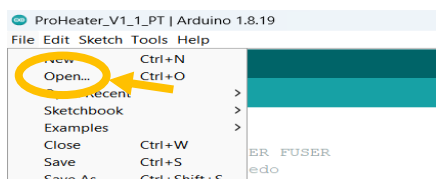

From *File*, load (*Open*) the provided project (.ino file).

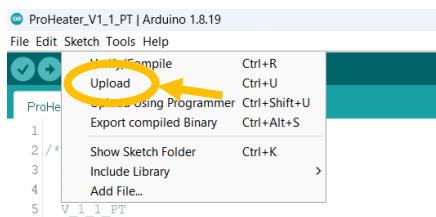

Upload the sketch to the CPU module.

After the upload, disconnect the USB cable and assemble the front panel.

Turn the machine On. It should be running the new firmware.